

Infinity "Pogo" Plus Pump

Pump #812490, #812491 (Drum (SS)), #812500, #812501 (Stub (SS)),
Ratio 2:1 – 200 PSI SS = Stainless Steel, CS = Carbon Steel

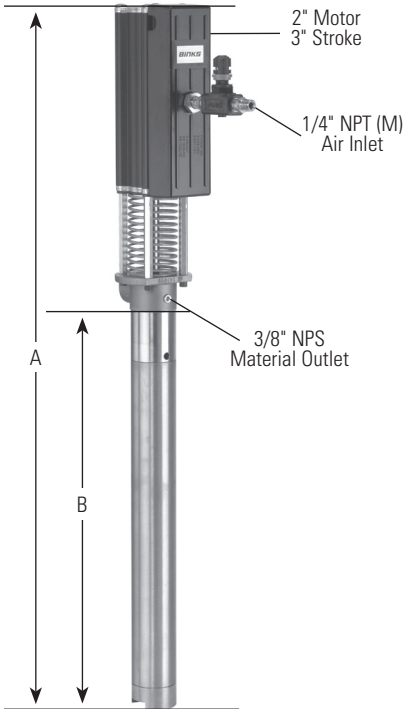

POGO Plus

Performance – 200 PSI

Air Inlet Pressure 0 - 150 PSI (0 - 10.3 bar)
Fluid Pressure Range 0 - 300 PSI (0 - 24.2 bar)
Max. Cycles/Min. 120
Displacement Per Cycle 8.28 cu. in.
Volume Per Cycle. 4.59 oz. (135.6 ml)
Cycles Per Gallon (Liter) 27.9
Flow @ 60 Cycles/Min. 2.15 GPM (8.14 lpm)

Materials of Construction 81249X and 81245X (SS)

Noise Level @ 100 PSI 80 db(A)
Lower Pump Material Stainless Steel
Plunger Material 300 Series SS
Cylinder Material Stainless Steel
812490, 812500 Packing Set. .UHMW Polyethylene
Max. 120° F Fluid Inlet Temp. (Standard)
812491, 812501 Packing Set. PTFE
Weight Drum 22.5 lbs. (10.2 kgs.)
Stub 17.2 lbs. (7.8 kgs.)

Part Numbers for 81249X and 81245X (SS)

Air Motor 842010
Air Motor Repair Kit 861150
Lower Pump Assembly (End Series)
Lower Pump Repair Kit UHMW 861140
Lower Pump Repair Kit PTFE 861141

Materials of Construction 81247X and 81248X (CS)

Lower Pump Material Carbon Steel
Plunger Material ... Carbon Steel (Chrome Plated)
Cylinder Material Carbon Steel
812470, 812480 Packing Set. .UHMW Polyethylene
Max. 120° F Fluid Inlet Temp. (Standard)
812471, 812481 Packing Set. PTFE
Weight Drum 19.6 lbs. (8.9 kgs.)
Stub 17.5 lbs. (7.9 kgs.)

Available Accessories

Air Control 41-15931
Wall Mount or Open Drum Mount Bracket. . . 873184

Dimensional Data

MODEL	A (mm)	B (mm)	Weight (kg)
81249X●	47-3/4" (1211.8)	33-11/16" (855.6)	22.5 (10.2)
81250X▲	33-7/8" (859.9)	19-7/8" (503.7)	17.2 (7.8)

Capacity: ● 55 Gal. ▲ 5 Gal.

*All Pogo Pumps come complete and ready to use.

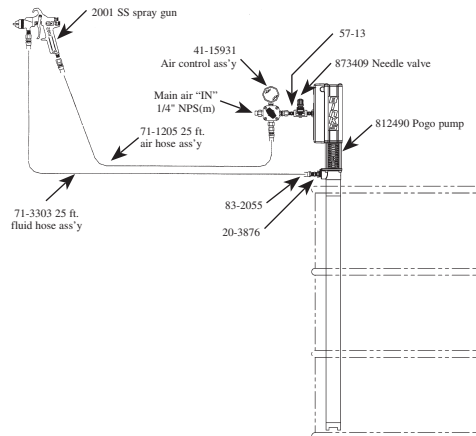
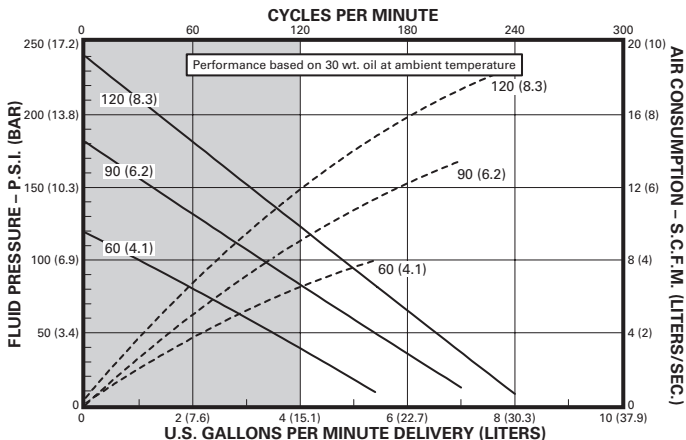

Pogo Plus Spray Finishing Outfit Model #98-3061

General Description

Excellent for solvent based adhesives. This (55) gallon bung system is complete with 2100 SS gun w/66SS x 66SD-3 set-up, 2:1 ratio supply pump with air control and 25 ft. fluid and air hose assemblies.