

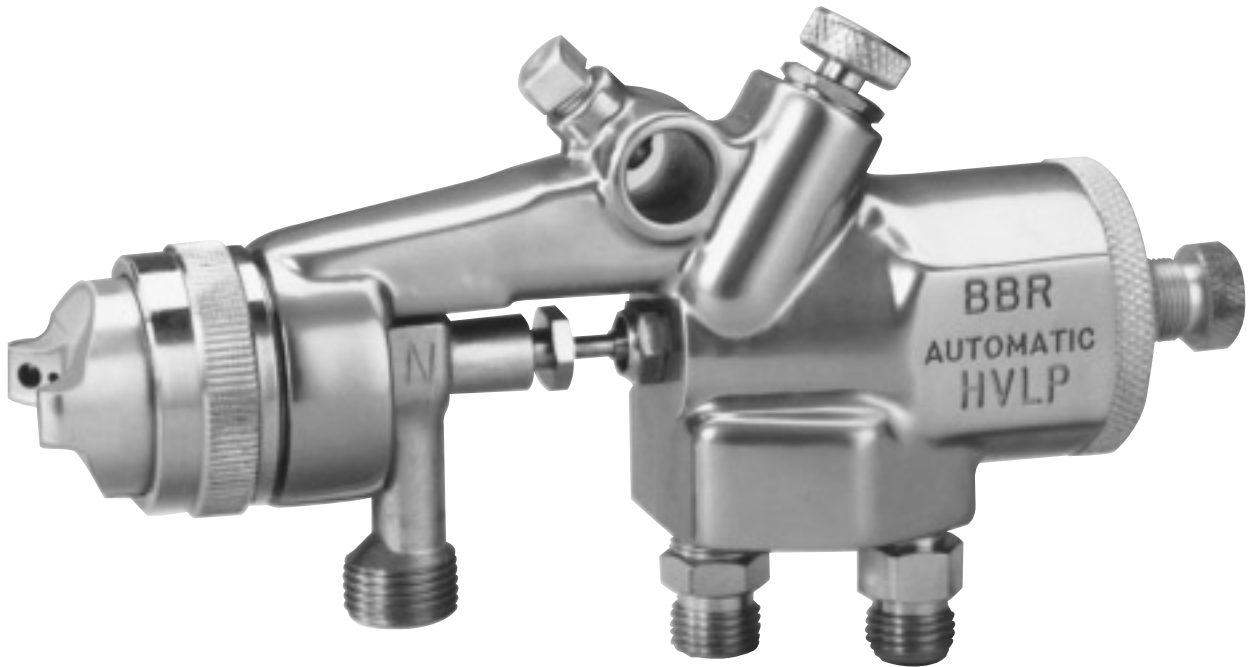

# MACH 1A HVLP (MACH 1AV HVLP) Automatic Airspray Gun



Your new Binks MACH 1A HVLP Automatic Spray Gun is exceptionally rugged in construction, and is built to stand up under hard, continuous use. However, like any other fine precision instrument, its most efficient operation depends on a knowledge of its construction, operation and maintenance. Properly handled and cared for, it will produce beautiful, uniform finishing results long after other spray guns have worn out.

The automatic MACH 1A HVLP gun is a conventional style airspray gun with special nozzles and modifications that allow it to operate at high transfer efficiencies in compliance with the "California South Coast Air Quality Management District" regulations as a "high volume, low pressure" airspray gun.

High pressure, low volume airflow is converted to high volume, low pressure within the gun body. Special air and fluid nozzles enable the gun to atomize fluid at low air pressures and velocities, creating the "soft spray" effect for high transfer efficiencies.

## **⚠ CAUTION**

Before removing any components from spray gun, shut off air and material pressure.

## **NOTE**

IMPORTANT REGULATORY NOTE regarding the use of this product appears on page 8.

Replaces  
Part Sheet  
2467R-3

Part  
Sheet  
2467R-4

## Binks MACH 1A HVLP AUTOMATIC SPRAY GUN

Typical Arrangement Diagram and Hook-up for Combined Fan and Atomizing Air

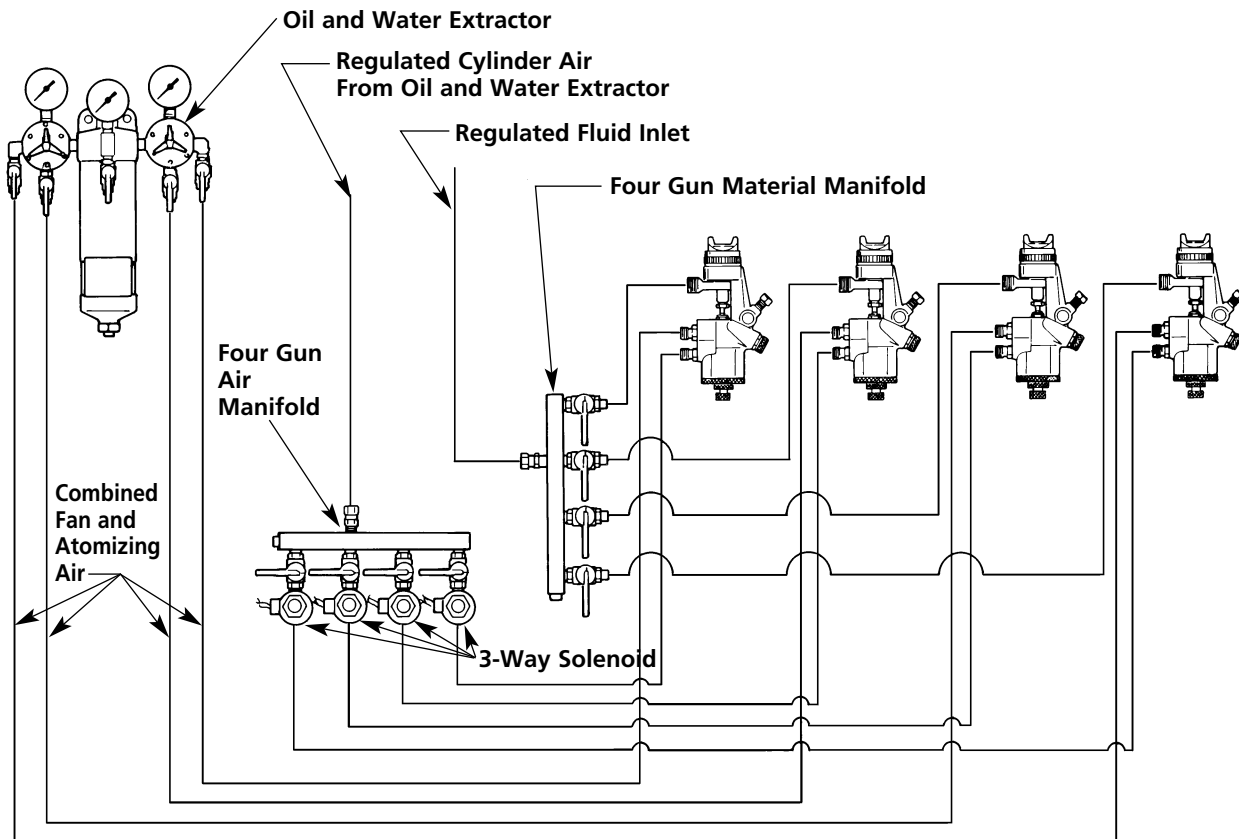
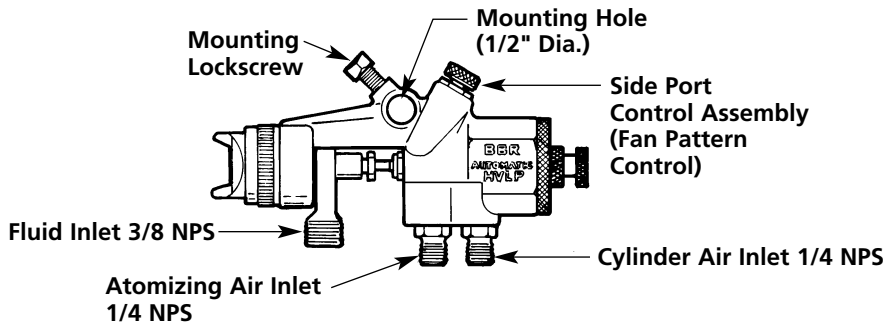
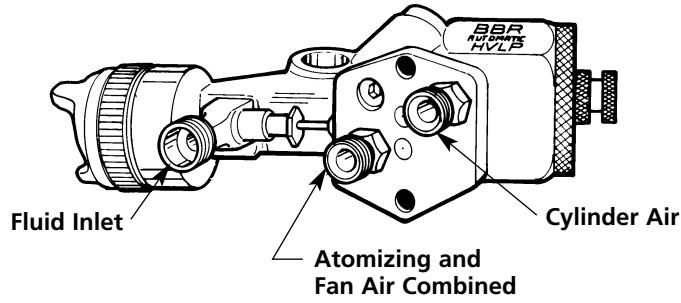

For some applications each gun may require individually regulated fluid and air inlet lines.

## Binks MACH 1A HVLP AUTOMATIC SPRAY GUN

Typical Arrangement Diagram and Hook-up for Separate Fan and Atomizing Air  
(See Page 4 for Internal Modifications to Gun)

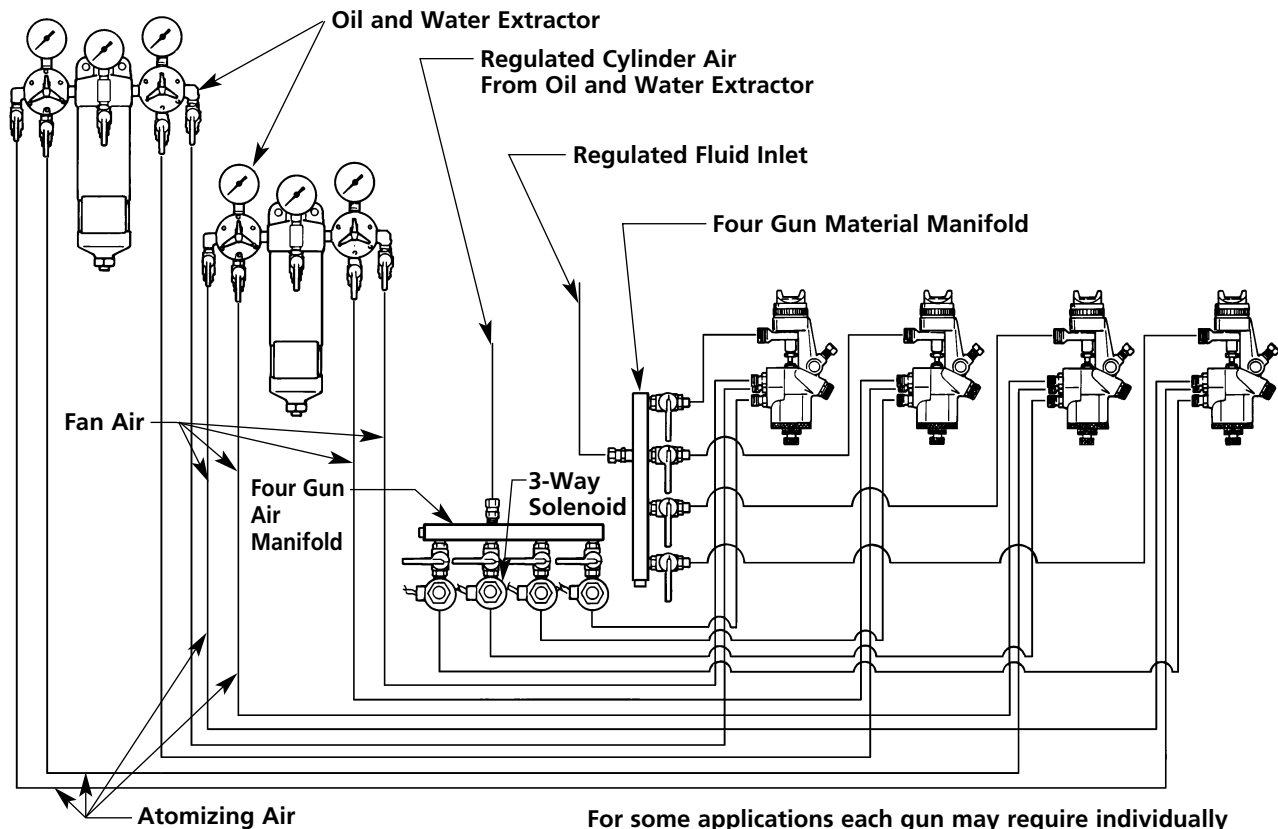
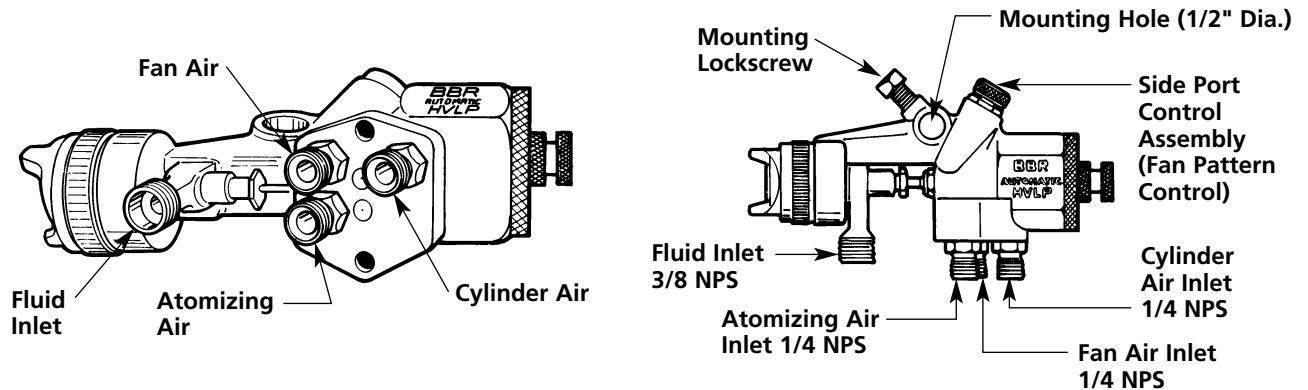

### GENERAL NOTES

1. Have at least 55-60 P.S.I. air pressure for cylinder's operating air.
2. To reduce overspray and obtain maximum efficiency, always spray with lowest possible air pressure that produces an acceptable spray pattern. Fluid pressure should be less than air pressure in most applications.
3. The air line from gun to 3-way valve should be as short as possible for rapid operation.
4. All air used in the gun should be dirt and moisture free. (This is accomplished by using an oil and water extractor).
5. Shut off all fluid and air lines to gun if gun is to stand idle for any length of time. (This is to prevent "build-up" or accumulation of minute leaks in the system from turning on the gun.)

## TO CHANGE FROM COMBINED FAN AND ATOMIZING AIR TO SEPARATE FAN AND ATOMIZING AIR

1. Unscrew end cap (27) and remove material needle valve (21, 22, 23, 24) (See parts drawing, page 6).
2. Remove piston (19) by injecting low pressure air into cylinder air port (A).

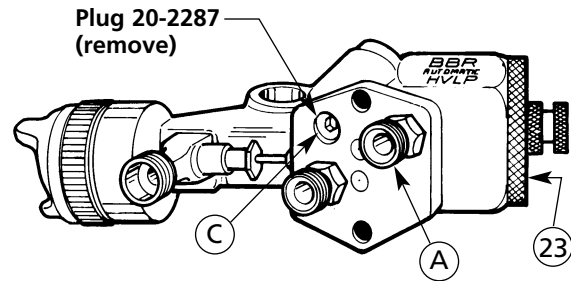

### ⚠ WARNING

Use of excessive pressure will cause piston to exit gun body at high velocity, possibly resulting in damage to the components or personal injury. Point back of the gun in a safe direction and do not use excessive pressure to remove the piston.

3. With 5/32" Allen wrench, remove plug (20-5692) from hole (B) on inside of cylinder.
4. Insert set screw (20-2141) into position as shown in side cut-away.
5. Re-install plug (20-5692).
6. Re-install piston, 2 springs, material needle valve and end cap (27). (See assembly drawing, page 6).
7. Remove plug 20-2287 from the fan air port (C).
8. Install fitting 71-28 into port (C).

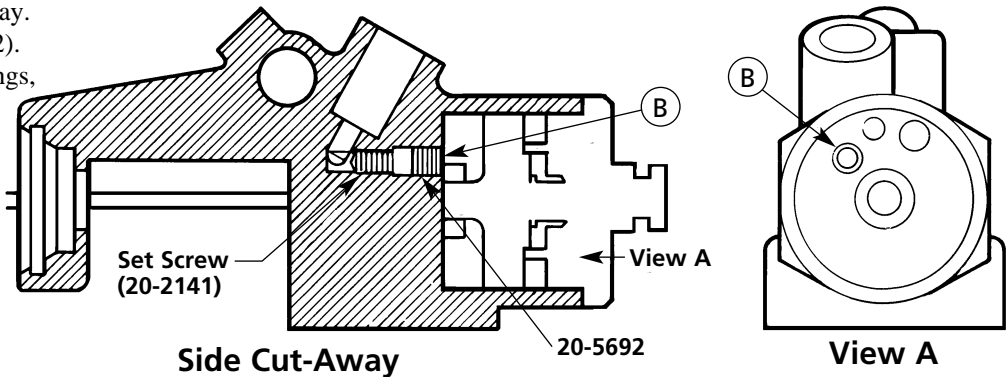

## SETUP FOR SPRAYING

### CONNECTING GUN TO MATERIAL HOSE

Gun should be connected by a suitable length of 3/8" diameter material hose fitted with a connector with a 3/8" NPS(f) nut at gun end. 1/4" diameter hose is recommended for use with low viscosity materials. (Fluid hoses of different composition are available for special fluids.)

### CONNECTING GUN TO AIR HOSE

Gun should be connected by a suitable length of 5/16" diameter air hose fitted with a connector with a 1/4" NPS(f) nut at gun end.

## OPERATING THE MACH 1 HVLP AUTOMATIC SPRAY GUN

### CONTROLLING THE MATERIAL FLOW

When fed from a pressure supply, an increase in the material pressure will increase the rate of flow. Correct fluid nozzle size ensures correct material flow rate. If necessary, fluid flow can also be adjusted by adjusting the amount of needle travel. This is done by loosening lock nut (28) and adjusting control knob (29) until the correct needle travel is achieved.

### ADJUSTING AIR AND FLUID TIMING

A 1/16" gap between the air piston (19) and needle body (23) should be maintained (see figure 1). This will create needle motion that will allow adequate air flow before the fluid starts flowing. The gap may be adjusted by partially removing the material needle valve (21, 22, 23, 24), screwing the needle (21) either in or out of the needle body (23) and locking it back into the gun while being sure to check the clearance between the air valve piston (19) and the needle body (23).

### ADJUSTING THE SPRAY PATTERN

The width of the spray pattern is controlled by the side port control assembly (7) on page 6. Turning this control clockwise until it is closed will give a round spray; turning it counterclockwise will widen the spray into a fan shape. The fan spray can be turned anywhere through 360° by positioning the air cap (2) relative to the gun. To effect this: loosen retainer ring; position nozzle, then, re-tighten retainer ring.

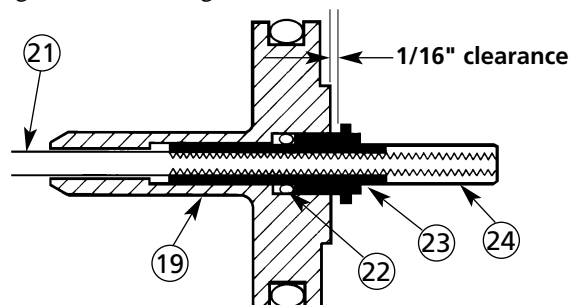

Figure 1

## NOZZLE AND NEEDLE SELECTIONS

### HVLP Air Nozzles

#### MODELS 95P, 97P, 905P, 907P, 95AP, 97AP

GUN INLET PRESSURE PSI	NOZZLE ATOMIZING AIR FLOW SCFM	APPROX. NOZZLE ATOMIZING PRESSURE PSI
30	11.0	3
50	15.7	5
65	19.6	9
70	22.5	10

95P = Standard pressure nozzle for fine finish spraying.  
 97P = Wide fan nozzle for fine finish of high solid coatings.  
 905P = Same as 95P but for use w/900 series fluid nozzle.  
 907P = Same as 97P but for use with 900 series nozzles.  
 95AP = Extra fine atomization nozzle for standard finish materials.  
 97AP = Extra fine atomization nozzle for high solids/metallics.

#### HVLP AIR NOZZLE 90P

NOZZLE ATOMIZING PRESSURE	NOZZLE AIRFLOW SCFM	#6 (STANDARD) SIDE PORT CONTROL GUN INLET PSI
3	4.0	5
5	4.5	7
7	5.0	10
9	5.5	12
10	6.0	15

### FLUID NOZZLES

#### STANDARD NOZZLES

MATERIAL	FLUID NOZZLE NO.	APPLICABLE AIR NOZZLES	COMPATIBLE FLUID NEEDLE†
<b>ULTRA LIGHT:</b> Reduced Flow.	89 (.020" Dia.)	90P, 92P	47-478
<b>VERY LIGHT:</b> Reduced Flow.	90 (.030" Dia.)	93P, 94P	47-478
<b>LIGHT:</b> less than 15 to 20 seconds in a ZAHN 2 Cup, e.g., stains, varnishes, thin lacquers, automotive refinishing materials.	91 (.040" Dia.)	95P, 97P	47-478
	92 (.046" Dia.)	95AP*	47-478
<b>MEDIUM:</b> 20 to 60 seconds in a ZAHN 2 Cup, e.g., general industrial coatings	94 (.055" Dia.)	97AP*	47-478
<b>HEAVY:</b> greater than 60 seconds in a ZAHN 2 Cup.	97 (.070" Dia.)		47-478

\*"Blue Max" fine finish nozzles.

#### SPECIAL PURPOSE NOZZLES

TYPICAL APPLICATION	FLUID NOZZLE NO.	APPLICABLE AIR NOZZLES	COMPATIBLE FLUID NEEDLE
<b>VERY HEAVY MATERIALS:</b> Block Filler, Texture Coatings, Fire Retardants, Road Marking Paint, Bitumastics, Adhesives, Cellular Plastics, Underbody and Vitreous Coatings, Special Applications	94VT (.052")▲ 1.3 mm	94P, 97P	54-3966
	901VT (.066")▲ 1.6 mm	905P, 907P	54-3967
	903 (.079") 2.0 mm		47-478†
	905 (.089") 2.0 mm		47-478†
	905VT (.088")▲ 2.3 mm		54-3968
	906 (.100") 2.5 mm		47-478†
	909 (.111") 2.8 mm		47-478†
<b>FEATHERING</b> For applications requiring more gradual valve opening for fluid flow control with trigger	909VT (.112")▲ 2.9 mm		54-3969
	90F (.030") 0.8 mm	94P, 97P 95AP, 97AP	54-4032
	91F (.040") 1.0 mm		54-4033
	92F (.046") 1.2 mm		54-4034
	94F (.055") 1.4 mm		54-4036
97F (.070") 1.7 mm	54-4039		

†Stainless steel, standard. Optional nylon tipped stainless steel (47-472) or optional square tip needle (54-4399) also available.  
 ▲ Carbide Tip – used on MACH 1AV gun.

#### LVLP AIR NOZZLES – 92P

GUN INLET PSI	NOZZLE AIRFLOW SCFM	NOZZLE ATOMIZING PSI
5.5	4.5	3
10.0	6.0	5
13.0	6.8	7
16.0	7.5	9
17.5	8.0	10

92P is for general industrial and automotive finish applications.

#### HVLP AIR NOZZLES – 93P

NOZZLE ATOMIZING PSI	NOZZLE AIR FLOW SCFM	#6 (STANDARD) SIDE PORT CONTROL	
		GUN INLET PSI	REGULATOR* PSI
3	5.5	8.0	10.0
5	7.0	11.5	14.0
7	8.0	14.5	18.0
9	9.5	17.0	22.5
10	10.0	18.0	24.0

#### HVLP AIR NOZZLES – 94P

NOZZLE ATOMIZING PSI	NOZZLE AIR FLOW SCFM	#6 (STANDARD) SIDE PORT CONTROL GUN INLET PSI
3	7	1
5	9	21
7	11	27
9	12	30
10	13	33

**Note:** Regulator pressures are based on 25' of 5/16" diameter hose in good condition without Quick-Disconnects or other restrictive fittings. Use the air nozzle test gauge accessory to confirm the atomizing/regulator pressure relationship for your actual air supply set-up. These recommendations are for "typical" or "average" fluids, and are intended to serve as a starting point. Adjust as necessary for your specific application.

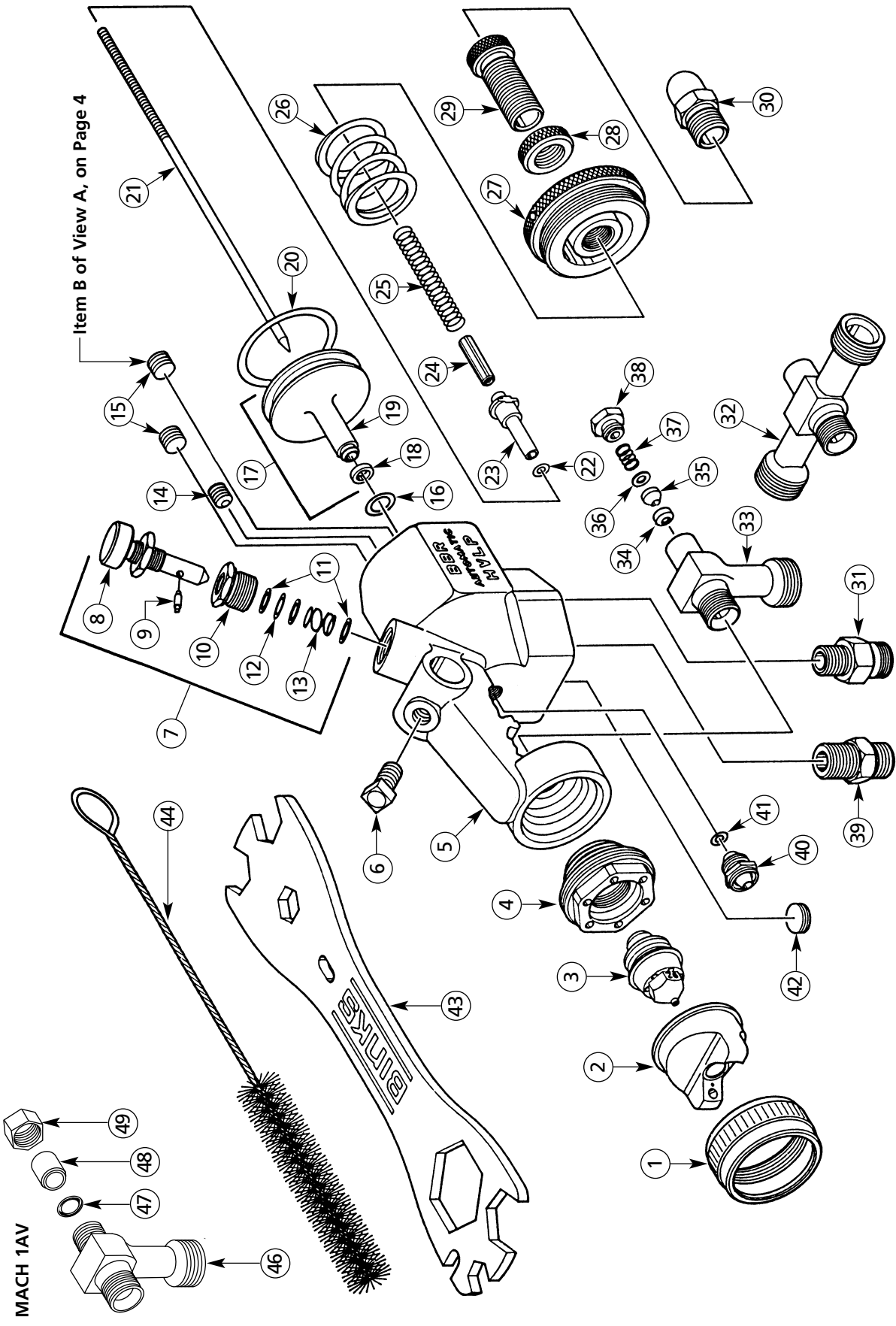

Optional fluid needle cover (30) is for installations that need to be tamper-proof.  
 Needle cover allows gun to be fully opened when triggered.

## PARTS LIST

(When ordering, please specify Part No.)

ITEM NO.	PART NO.	DESCRIPTION	QTY.	ITEM NO.	PART NO.	DESCRIPTION	QTY.
1	54-3531	RETAINING RING.....	1	27	54-3708	END CAP.....	1
2	*	AIR NOZZLE.....	1	28	54-3732	LOCK NUT.....	1
3	*	FLUID NOZZLE.....	1	29	54-3731	CONTROL KNOB.....	1
4	54-3543	HEAD INSERT.....	1	30	54-3715**	FLUID NEEDLE COVER.....	1
5	54-3975	MACH 1A GUN BODY ASSEMBLY..	1	31	71-28	DOUBLE MALE NIPPLE 1/8 NPT x 1/4 NPS.....	2
6	20-1359	SQ. BOLT 5/16-18 x 3/4 Long.....	1	32	54-3741	FLUID INLET, RECIRCULATING (Optional).....	1
7	54-3720	SIDE PORT CONTROL ASSEMBLY..	1	33	54-3533	FLUID INLET (Stainless Steel).....	1
8	54-3721	CONTROL SPINDLE.....	1	34	54-4264●▲	GLAND ADAPTER.....	1
9	31-258	RETAINING PIN.....	1	35	54-4265●▲	NEEDLE SEAL.....	1
10	31-256	STUFFING BOX.....	1	36	54-4266●▲	SEAL BACKUP.....	1
11	31-259	INNER WASHER.....	3	37	54-4267●▲	SPRING.....	1
12	20-3620▲	O-RING.....	1	38	54-4263●▲	PACKING NUT.....	1
13	31-241	CONTROL SPRING.....	1	39	57-13	DOUBLE MALE NIPPLE 1/4 NPT x 1/4 NPS.....	1
14	20-5589△	PLUG.....	1	40	54-3716	AIR VALVE GLAND ASSEMBLY.....	1
15	20-5692△	PLUG 1/16-20 NPT.....	2	41	20-3859▲	O-RING Air Valve Gland.....	1
16	20-5286▲	O-RING.....	1	42	20-2287	PLUG 1/8-27 NPT.....	1
17	54-3706	PISTON ASSEMBLY.....	1	43	54-3918	WRENCH (Not Included).....	1
18	54-3729◆	SEAL.....	1	44	82-469	GUN BRUSH (Optional).....	1
19	54-3722◆	PISTON.....	1	45	54-4269	JAM NUT.....	1
20	20-4511▲	O-RING.....	1	46	54-4541■	FLUID INLET.....	1
21	47-478	NEEDLE (Stainless Steel).....	1	47	20-2227■▲	O-RING.....	1
22	20-3515▲	O-RING (Needle Assembly).....	1	48	54-4531■▲	SPACER.....	1
23	54-3713	NEEDLE BODY.....	1	49	54-4542■	NUT ASSEMBLY.....	1
24	54-3709	NEEDLE LOCKING NUT.....	1		54-4270	NEEDLE BOOT (Optional, Not Shown)	1
25	54-3719	SPRING (Needle Return).....	1				
	54-4096	OPTIONAL H.D. SPRING (Needle Return)	1				
26	54-3707	SPRING (Piston Return).....	1				
	54-1876	OPTIONAL H.D. SPRING (Piston Return)	1				

\* See Air and Fluid Nozzle Chart on page 5.

\*\* Optional fluid needle cover is for installations that need to be tamper-proof. Needle cover allows gun to be fully opened when triggered.

▲ Part of Repair Kit 54-3980.

◆ Part of item 17. Also available separately.

● Part of Self-Adjusting Packing Kit (54-4261) without needle.

△ Part of gun body assembly, item 5. ■ For MACH 1AV.

## MAINTENANCE

### LUBRICATION

Monthly: Remove piston assembly (17) and lubricate the air cylinder chamber and needle valve spring with a coating of petroleum jelly. Also, lubricate side port control assembly (7) with oil. Binks Gunners Mate (54-3871) is recommended.

### CAUTION

Never use lubricants containing silicone since these lubricants can cause finish defects.

### REMOVAL OF PISTON

First unscrew the end cap (27), remove the springs (25 & 26) and pull out the entire material needle valve (21, 22, 23, 24). Remove piston by applying a few pounds of air pressure to the cylinder air inlet. Air pressure will cause the piston to pop out.

### WARNING

Use of excessive pressure will cause piston to exit gun body at high velocity, possibly resulting in damage to the components or personal injury. Point back of the gun in a safe direction and do not use excessive pressure to remove the piston.

### TO REPLACE NEEDLE SEAL AND GLAND ADAPTER IN FLUID INLET

Remove end cap (27), springs (25 & 26) and assembled material needle valve consisting of (21, 22, 23, 24). Proceed to the front of the gun and remove retaining ring (1), air nozzle (2) and fluid nozzle (3). Then, using wrench (43), unscrew head insert (4) and remove fluid inlet (33). Unscrew packing nut (38) and remove spring (37) and seal backup (36). Using a No. 10 x 1-1/4" coarse thread wood screw (Binks Part No. 20-6536) or small sheet metal screw, remove the needle seal (35) and gland adapter (34).

Replace gland adapter (34) and needle seal (35). Re-insert seal backup (36), spring (37) and screw on packing nut (38) a couple of turns so it fits loosely by hand. Reassemble fluid inlet (33) to gun body (5) with head insert (4). Tighten head insert using wrench (43). Reassemble fluid nozzle (3), air cap (2) and retaining ring (1). Re-insert material needle valve (21, 22, 23, 24), springs (25 & 26) and screw on end cap (27). Finally, tighten packing nut (38) until it bottoms out on fluid inlet (33).

## CLEANING

In certain states it is now against the law to spray solvents containing Volatile Organic Compounds (VOC) into the atmosphere when cleaning a spray gun.

In order to comply with these new air quality laws Binks recommends one of the following two methods to clean your spray finishing equipment:

1. Spray solvent through the gun into a closed system. An enclosed unit, or spray gun cleaning station, condenses sol-

vent vapors back into liquid form which prevents escape of VOC into the atmosphere.

2. Place spray gun in a washer type container. This system must totally enclose the spray gun, cups, nozzles, and other parts during washing, rinsing, and draining cycles. This type of unit must be able to flush solvent through the gun without releasing any VOC vapors into the atmosphere.

(Continued)

## CLEANING (Continued)

Additionally, open containers for storage or disposal of solvent, or solvent-containing cloth or paper, used for surface preparation and clean-up may not be used. Containers shall be non absorbent.

### CLEANING

To clean the gun, flush the fluid lines with solvent and blow air

through the lines to make sure all the air passages are dry.

### CAUTION

Never completely submerge the gun in solvent as this will dissolve the lubricating oil and dry out the seals.

## TROUBLE SHOOTING

### FAULTY SPRAY

A faulty spray may be caused by improper cleaning, dried materials around the fluid nozzle tip or in the air cap. Soak these parts in thinners that will soften the dried material and remove with a brush or cloth. If either the air cap (2) or fluid nozzle (3) are damaged, these parts must be replaced before perfect spray can be obtained.

### CAUTION

Never use metal instruments to clean the air or fluid nozzles, these parts are carefully machined and any damage to them will cause faulty spray.

### INTERMITTENT SPRAY

If the spray flutters, it is caused by one of the following faults:

1. Insufficient material available. Check supply and replenish if necessary.
2. Loose fluid nozzle (3). Tighten but without using undue force (100-120 in. lbs. torque).
3. Leakage at material needle valve packing (40). Tighten or replace air valve gland assembly.
4. Fluid connection insufficiently tight or dirt on cone faces of connection. Correct as necessary.
5. Leaking cylinder air and/or inadequate pressure.
6. Inadequate fluid pressure.

### AIR NOZZLE TEST GAUGE ASSEMBLY

54-3935 for 95P, 97P, 95AP, and 97AP Nozzles.

54-3908 for 900 Series Nozzles.

54-4345 for 90P Air Nozzle.

54-4356 for 93P Air Nozzle.

54-3902 for 91P and 92P Air Nozzles.

54-4066 for 94P Air Nozzle.

### CAUTION

Do not exceed 70 psi gun inlet pressure. Use air nozzle test gauge assembly to determine and verify exact nozzle operating air pressure.

### GUN DIMENSIONS

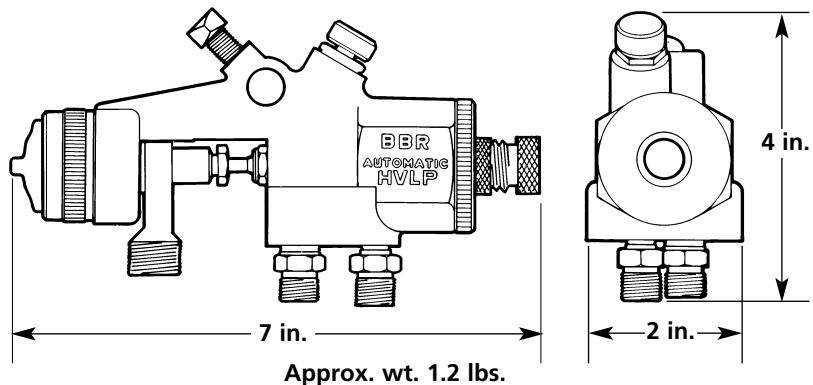

### IMPORTANT REGULATORY NOTE

Some regulatory agencies prohibit the operation of HVLP spray guns above 10 PSI nozzle atomizing pressure. Users subject to this type of regulation should not exceed 10 PSI (50 PSI gun inlet pressure). It is recommended that the air nozzle test gauge assembly (at right) be used to confirm actual nozzle operating pressure.

It may also be a requirement of some regulatory agencies that users have this gauge nozzle available on site to verify that the gun is being operated within the limits of applicable rules.

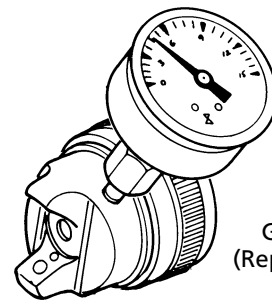

Sales and Service Through a Nationwide Network of Industrial Distributors.

**Customer Service in USA / 1-800-992-4657**  
**Technical Support in USA / 1-888-992-4657**



195 Internationale Blvd.  
Glendale Heights, IL 60139

2467R-4 Revisions: (P5) Updated All Charts; (P6) removed part no. 31 from illustration; (P7) revisions to Parts List; (P8) Updated printing date.

Part Sheet 2467R-4 Printed in USA 9/01, All Rights Reserved