

# SG2, SG3 Spray Guns

Models: 243011, 243012, 246506, 243238, 243382, 289843, 257359

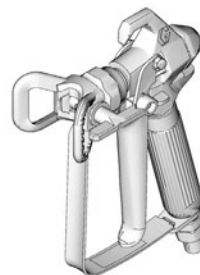

312830E  
ENG



ti11562a



**IMPORTANT SAFETY INSTRUCTIONS.** Refer to your sprayer instruction manual for Pressure Relief, priming and spray instructions. Keep these instructions.

Maximum Working Pressure: 3600 psi (248 bar, 24.8 MPa)

## - For the application of architectural paints and coatings -

The following Warnings are for the setup, use, grounding, maintenance and repair of this equipment. The exclamation point symbol alerts you to a general warning and hazard symbols refer to procedure-specific risks. Refer back to these Warnings. Additional, product-specific warnings may be found throughout the body of this manual where applicable.



### WARNINGS



#### SKIN INJECTION HAZARD

High-pressure fluid from gun, hose leaks, or ruptured components will pierce skin. This may look like just a cut, but it is a serious injury that can result in amputation. **Get immediate surgical treatment.**

- Do not point gun at anyone or at any part of the body.
- Do not put your hand over the spray tip.
- Do not stop or deflect leaks with your hand, body, glove, or rag.
- Do not spray without tip guard and trigger guard installed.
- Engage trigger lock when not spraying.
- Follow **Pressure Relief Procedure** in this manual, when you stop spraying and before cleaning, checking, or servicing equipment.



#### FIRE AND EXPLOSION HAZARD

Flammable fumes, such as solvent and paint fumes, in **work area** can ignite or explode. To help prevent fire and explosion:

- Use equipment only in well ventilated area.
- Eliminate all ignition sources; such as pilot lights, cigarettes, portable electric lamps, and plastic drop cloths (potential static arc).
- Keep work area free of debris, including solvent, rags and gasoline.
- Do not plug or unplug power cords, or turn power or light switches on or off when flammable fumes are present.
- Ground all equipment in the work area. See **Grounding** instructions.
- Use only grounded hoses.
- Hold gun firmly to side of grounded pail when triggering into pail.
- If there is static sparking or you feel a shock, **stop operation immediately**. Do not use equipment until you identify and correct the problem.
- Keep a working fire extinguisher in the work area.



#### EQUIPMENT MISUSE HAZARD

Misuse can cause death or serious injury.

- Do not operate the unit when fatigued or under the influence of drugs or alcohol.
- Do not exceed the maximum working pressure or temperature rating of the lowest rated system component. See **Technical Data** in all equipment manuals.
- Use fluids and solvents that are compatible with equipment wetted parts. See **Technical Data** in all equipment manuals. Read fluid and solvent manufacturer's warnings. For complete information about your material, request MSDS forms from distributor or retailer.
- Check equipment daily. Repair or replace worn or damaged parts immediately with genuine manufacturer's replacement parts only.
- Do not alter or modify equipment.
- Use equipment only for its intended purpose. Call your distributor for information.
- Route hoses and cables away from traffic areas, sharp edges, moving parts, and hot surfaces.
- Do not kink or over bend hoses or use hoses to pull equipment.
- Keep children and animals away from work area.
- Comply with all applicable safety regulations.



#### PRESSURIZED ALUMINUM PARTS HAZARD

Do not use 1,1,1-trichloroethane, methylene chloride, other halogenated hydrocarbon solvents or fluids containing such solvents in pressurized aluminum equipment. Such use can cause serious chemical reaction and equipment rupture, and result in death, serious injury, and property damage.



#### PERSONAL PROTECTIVE EQUIPMENT

You must wear appropriate protective equipment when operating, servicing, or in the operating area of the equipment to help protect you from serious injury. This equipment includes but is not limited to:

- Protective eyewear
- Clothing and respirator as recommended by the fluid and solvent manufacturer
- Gloves
- Hearing protection

## Pressure Relief Procedure



### WARNING



Follow this **Pressure Relief Procedure** whenever instructed to relieve pressure, stop spraying, check or service equipment, or install or clean spray tip.

1. Turn OFF power and turn sprayer pressure control to lowest pressure setting.
2. Hold gun against side of flushing pail. Trigger gun into pail to relieve pressure.

If you suspect spray tip or hose is clogged or that pressure has not been fully relieved after following the steps above, VERY SLOWLY loosen tip guard retaining nut or hose end coupling to relieve pressure gradually, then loosen completely. Clear hose or tip obstruction.

## Gun Trigger Lock



### WARNING



To prevent injury when the gun is not in use, always set the gun's trigger lock if unit is being shut down or left unattended.

Trigger Locked  
(no spray)

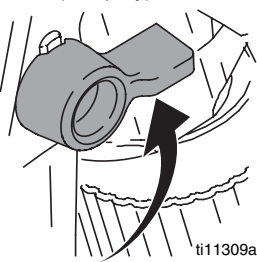

Trigger Unlocked  
(spray)



## Setup



### WARNING

Make sure sprayer is turned off and unplugged from power source. Refer to your sprayer instruction manual for priming and spray instructions.

### Connect Gun to Sprayer

1. Attach supply hose to sprayer fluid outlet.
2. Attach other end of supply hose to gun swivel (5). Use two wrenches (one on the swivel (5) and one on the hose), to tighten all connections securely.
3. Refer to sprayer instruction manual for priming instructions.

## Installing Tip (26) and Guard (25) on Gun



### WARNING



1. If equipment has recently been operated, **relieve pressure**. Set trigger lock.

2. Using a pencil or similar object, insert seal (24) into back of guard (25).
3. Install guard (25) over end of gun (1).
4. Insert tip (26) in guard (25). Tighten retaining nut.

## Operation

### Spraying

1. Unlock trigger lock.
2. Be sure the arrow shaped tip (26) faces forward (spray).
3. Hold gun perpendicular and approximately 12-inches (30 cm) from surface. Move gun first, then pull gun trigger (3) to spray a test pattern.
4. Slowly increase pump pressure until coverage is uniform and even (see sprayer instruction manual for additional information).

### Aligning Spray



### WARNING



1. **Relieve pressure**. Set trigger lock.

2. Loosen guard retaining nut.
3. Align guard (25) horizontally to spray a horizontal pattern.
4. Align guard (25) vertically to spray a vertical pattern.

(3) Horizontal

(4) Vertical

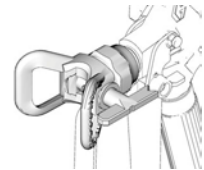
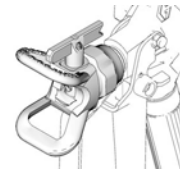

### Clearing Clogs



### WARNING

1. **Relieve pressure**. Set trigger lock.
2. Rotate tip (26) 180°. Unlock trigger lock. Trigger gun into pail or onto ground to remove clog.
3. Set trigger lock. Rotate tip (26) 180° back to spray position.

## Cleanup

Flush gun after each work shift and store in a dry location. Do not leave the gun or any parts in water or cleaning solvents.

# Parts

\*Kit 288817 repairs both series A and B guns.  
1a replaces these three components of series A.

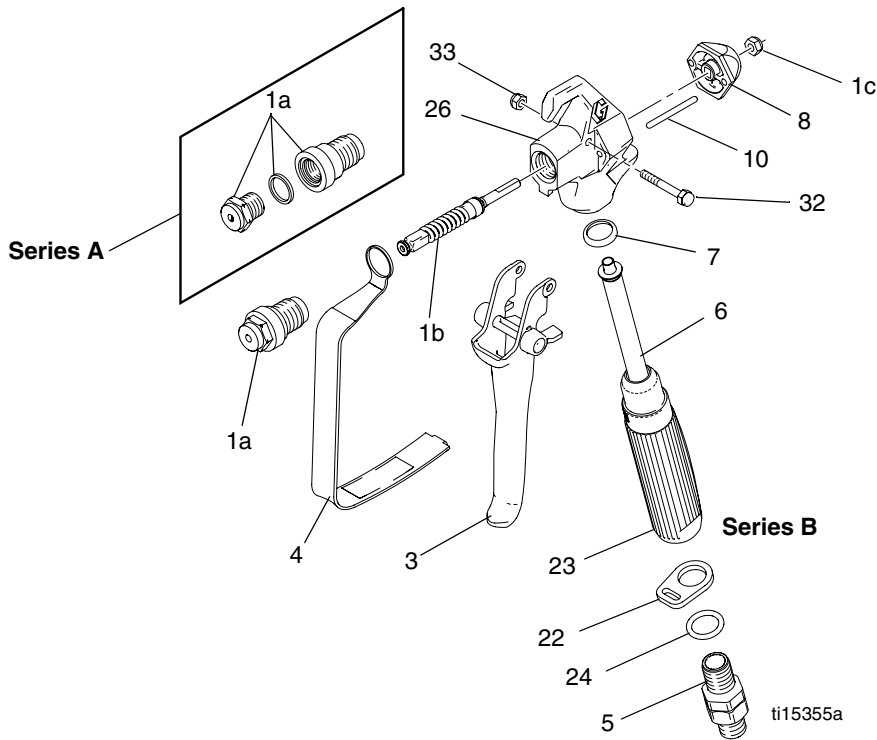

Ref.	Part	Description	Qty.	Ref.	Part	Description	Qty.
1	288817	KIT, repair, gun (includes 1a, 1b, 1c)	1	10	115484	PIN, actuator	2
1a		SEAT, valve	1	22	113409	RETAINER, guard	1
1b		NEEDLE, gun	1	23	195393	HANDLE, gun (SG2)	1
1c	115483	NUT, lock	1		195788	HANDLE, gun (SG3, SG3-E)	1
3	243639	TRIGGER, repair kit includes 32, 33	1		195920	HANDLE, gun (SG3-A)	1
4	195495	GUARD, trigger	1	24	115485	O-RING	1
5	238817	KIT, swivel	1	26	195389	HOUSING, fluid	1
	195384	ADAPTER, gun inlet (SG2)	1	32	177538	STUD, trigger	1
6✓	243084	FILTER, gun, SG2/SG3	1	33	105334	NUT, lock, hex	1
	218131	FILTER, gun, SG3-E/SG3-A	1				
7✓	179733	SEAL, sleeve	1				
8	195395	CAP, end	1				

▲ Replacement Warning labels, tags and cards are available at no cost.  
✓ Keep these spare parts on hand to reduce down time

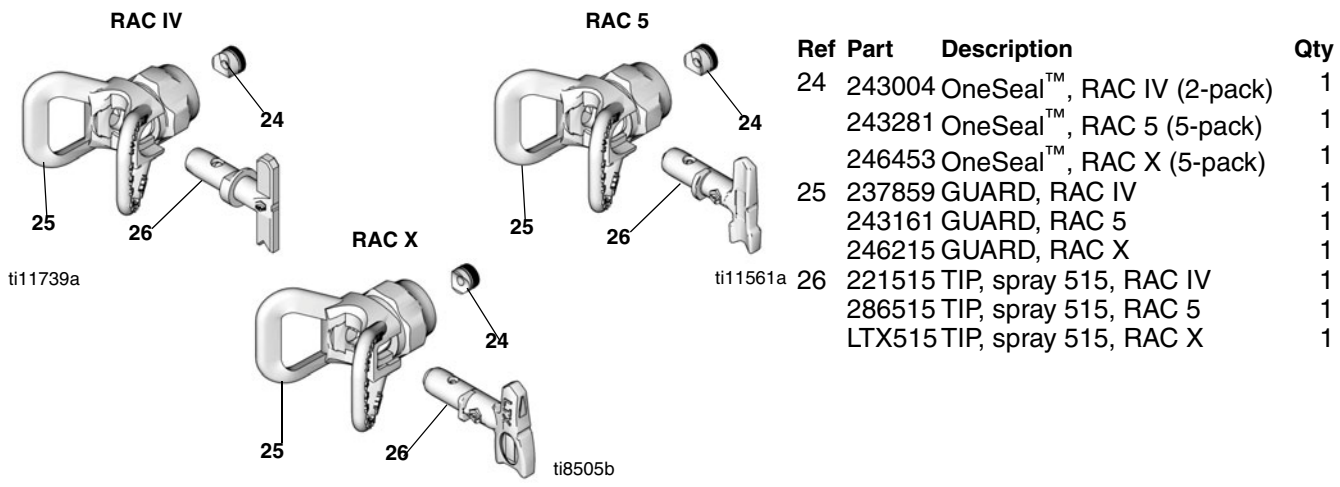

Ref	Part	Description	Qty
24	243004	OneSeal™, RAC IV (2-pack)	1
	243281	OneSeal™, RAC 5 (5-pack)	1
	246453	OneSeal™, RAC X (5-pack)	1
25	237859	GUARD, RAC IV	1
	243161	GUARD, RAC 5	1
	246215	GUARD, RAC X	1
26	221515	TIP, spray 515, RAC IV	1
	286515	TIP, spray 515, RAC 5	1
	LTX515	TIP, spray 515, RAC X	1

# Maintenance



## WARNING

Before performing any maintenance on gun, read all warnings on front cover of this manual and **relieve pressure**.

### Cleaning/Replacing Filter (6)



1. **Relieve pressure.** Set trigger lock

2. Disconnect fluid hose from gun at swivel (5).
3. Disconnect trigger guard (4) from guard retainer (22).
4. Unscrew handle (23) from gun (1).
5. Remove filter (6) through top of handle (23).
6. Clean filter (6). Use a soft brush to loosen and remove excess debris.
7. Insert clean filter (6) into handle (23).
8. Reattach handle (23) to gun (1). Tighten securely.
9. Reconnect trigger guard (4) to guard retainer (22).

### Translated Manuals

French - 312831	Estonian - 312845
Spanish - 312832	Latvian - 312846
Dutch - 312833	Lithuanian - 312847
German - 312834	Polish - 312848
Italian - 312835	Hungarian - 312849
Turkish - 312836	Czech - 312850
Greek - 312837	Slovakian - 312851
Croatian - 312838	Slovenian - 312852
Portuguese - 312839	Romanian - 312853
Danish - 312840	Bulgarian - 312854
Finnish - 312841	Chinese - 312855
Swedish - 312842	Japanese - 312856
Norwegian - 312843	Korean - 312857
Russian - 312844	

Translated manuals can be requested through a distributor or at [www.graco.com](http://www.graco.com).

### Technical Data

Maximum working pressure	3600 psi (248 bar, 24.8 MPa)
Fluid orifice size	0.125 in. (3.18 mm)
Weight (with tip and guard)	22 oz. (630 g)
Inlet	
Maximum material temperature	120 F (49 C)
Wetted Parts	Stainless steel, polyurethane, nylon, aluminum, tungsten carbide, brass
*Noise Level: Sound power	87 dBa
Sound pressure	78 dBa
*Measured at 3.1 ft (1m) while spraying water-based paint, specific gravity 1.36, through a 517 tip at 3000 psi (207 bar, 20.7 MPa) per ISO 3744	

For complete warranty information contact your local Graco distributor, call Graco customer service: 1-800-690-2894 or visit our website: [www.graco.com](http://www.graco.com).  
All written and visual data contained in this document reflects the latest product information available at the time of publication. Graco reserves the right to make changes at any time without notice.

Original instructions. This manual contains English. MM 312830

**Graco Headquarters:** Minneapolis  
**International Offices:** Belgium, China, Japan, Korea

**GRACO INC. P.O. BOX 1441 MINNEAPOLIS, MN 55440-1441**

**Copyright 2010, Graco Inc. is registered to ISO 9001**

[www.graco.com](http://www.graco.com)  
Revised 01/2011

# Repair

## Replacing Needle

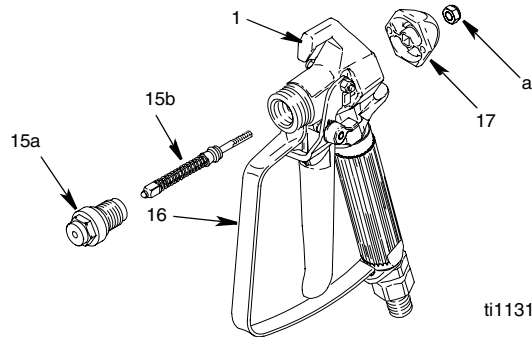

ti11311b



## WARNING

1. **Relieve pressure.** Set trigger lock.
2. Remove tip (26) and guard (25) from gun (1).
3. Disconnect fluid hose from gun at swivel (5).
4. Squeeze trigger while unscrewing diffuser.
5. Remove locknut and end cap.
6. Tap out needle.
7. Use a soft brush to clean out internal passages of gun.
8. Grease o-rings of new needle using a non-silicon grease.
9. Guide new needle (15b) through front of gun .
10. Install end cap and locknut, loosely.
11. For needle housing (15a), apply medium strength (blue) thread sealant to threads.
12. Squeeze trigger while installing needle housing. Torque to 26-32 ft-lb (35-43 N•m).
13. Hold gun with nozzle facing up.
14. Turn locknut (a) clockwise until you see and feel trigger (3) raise slightly.
15. Turn locknut (a) 3/4 turn counter-clockwise.  
**NOTE:** When needle is properly adjusted, trigger will move freely.
16. Connect fluid hose. Install tip (26) and guard (25).
17. Prime sprayer. See sprayer instruction manual.
18. Trigger gun into bucket until fluid flows from gun.
19. Release trigger (3). Fluid flow should stop immediately.
20. Set trigger lock.
21. Aim gun into bucket. Trigger gun. No fluid should flow.
22. If the gun fails tests, steps 19 and/or 21, relieve pressure and disconnect hose. Readjust needle. Repeat tests.